

Product: SF-1000 welding table

Index: W00-01-SF1000

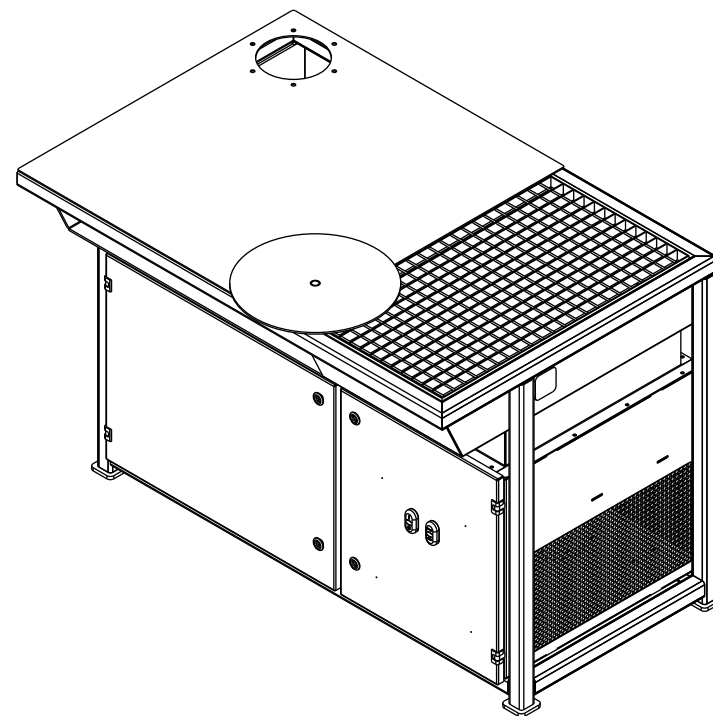
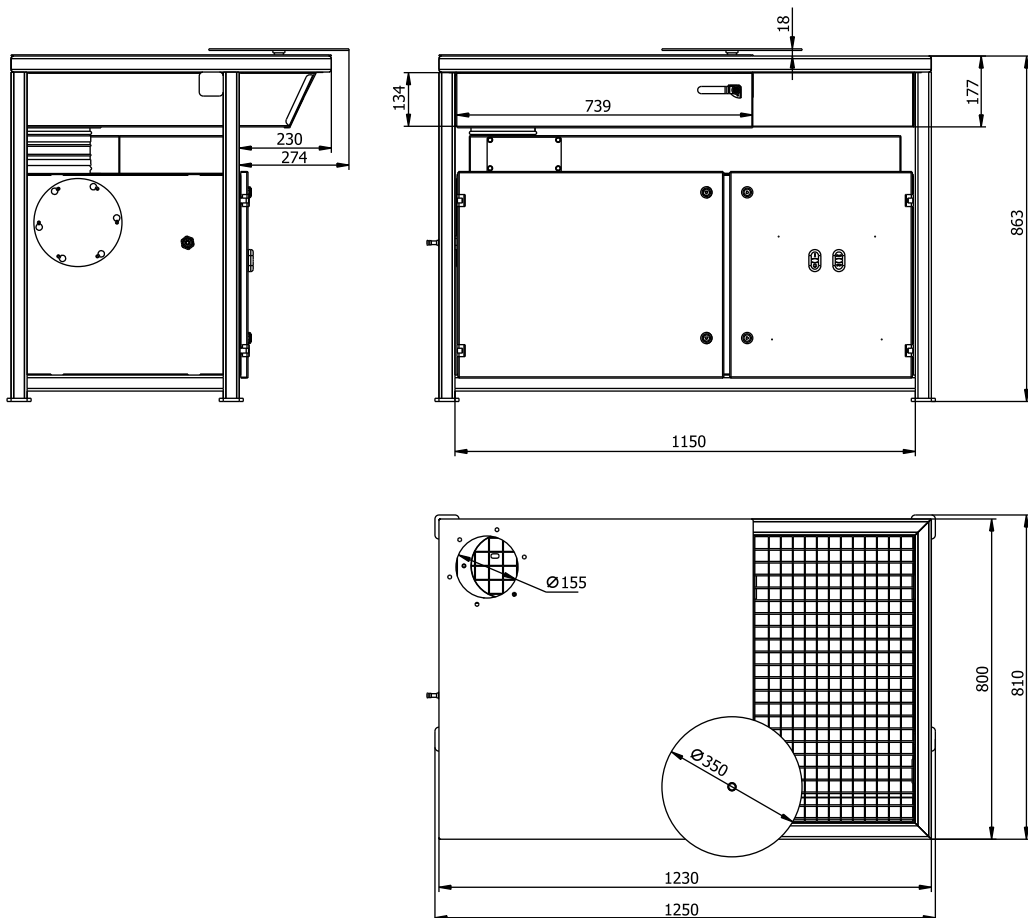

Construction:

- rigid, heavy duty, welded steel construction
- air pollution capture over and around the table with Oskar fume arm
- separate down draft built in the table
- easy to adjust airflow with two built in dampers (within the arm and table)
- optional revolving table on the table surface
- all parts powder coated
- ready to work with Oskar fume arm 160 models
- simple filter cartridges maintenance
- standard built-in compressed air cleaning system
- 1,1kW filter unit



Complete, heavy duty workbench with two exhausts for welding, cutting, grinding and many more for those who require reliable and long lasting protection from air pollution.

Product:	SF-1000 welding table
Index:	W00-01-SF1000



Construction:

- rigid, heavy duty, welded steel construction
- air pollution capture over and around the table with Oskar fume arm
- separate down draft built in the table
- easy to adjust airflow with two built in dampers (within the arm and table)
- optional revolving table on the table surface
- all parts powder coated
- ready to work with Oskar fume arm 160 models
- simple filter cartridges maintenance
- standard built-in compressed air cleaning system
- 1,1kW filter unit



Complete, heavy duty workbench with two exhausts for welding, cutting, grinding and many more for those who require reliable and long lasting protection from air pollution.