

OSKAR air products

www.oskarairproducts.com • info@oskarairproducts.com

ZWR-03 - 50 Hz fan unit

302-15-0001 • fan 0,75 kW, 3-phase, 400 V

Standard construction:

- impeller with backward inclined blades
- powder coated welded steel housing
- direct gas mixture temperature up to 40°C

Parameters:

power supply:	400V / 50Hz
motor power:	0,75 kW
nominal airflow:	1000 m ³ /h
rotation:	2780 RPM
insulation class:	F
protection:	IP54

Accessories and options:

- Mounting bracket WS-160
- Mounting bracket WSD-160 (extended)
- Motor on/off switch

Notes:

The method of packing and carton sizes:

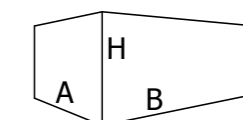

A = 640
B = 570
H = 520
weight = 25 kg

All dimensions are given in **mm**.

Menegon Sp z o.o.
Mokry Dwór 6C, 80-021 Wiślina, Polska
tel.: +48 58 3012838, fax +48 58 3059324
info@menegon.com.pl, www.menegon.com.pl



All rights reserved. This document including constructional and technical information as well as Oskar Air Products, Menegon and czystepowietrze.pl trademarks and brand names are law protected and are property of Menegon Sp. z o.o.

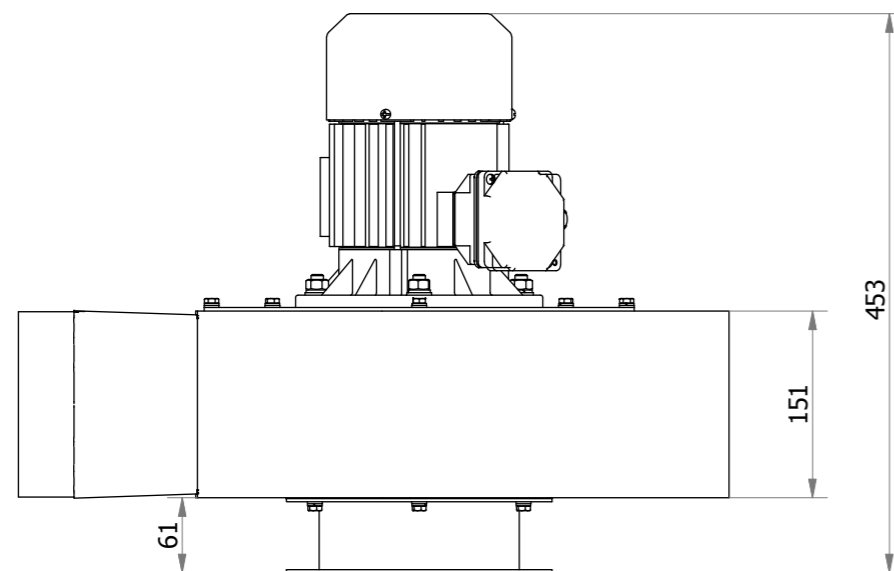
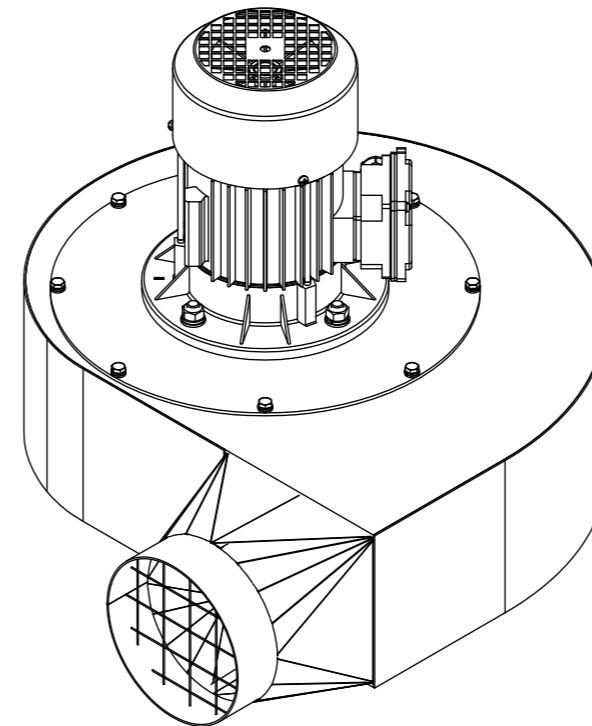
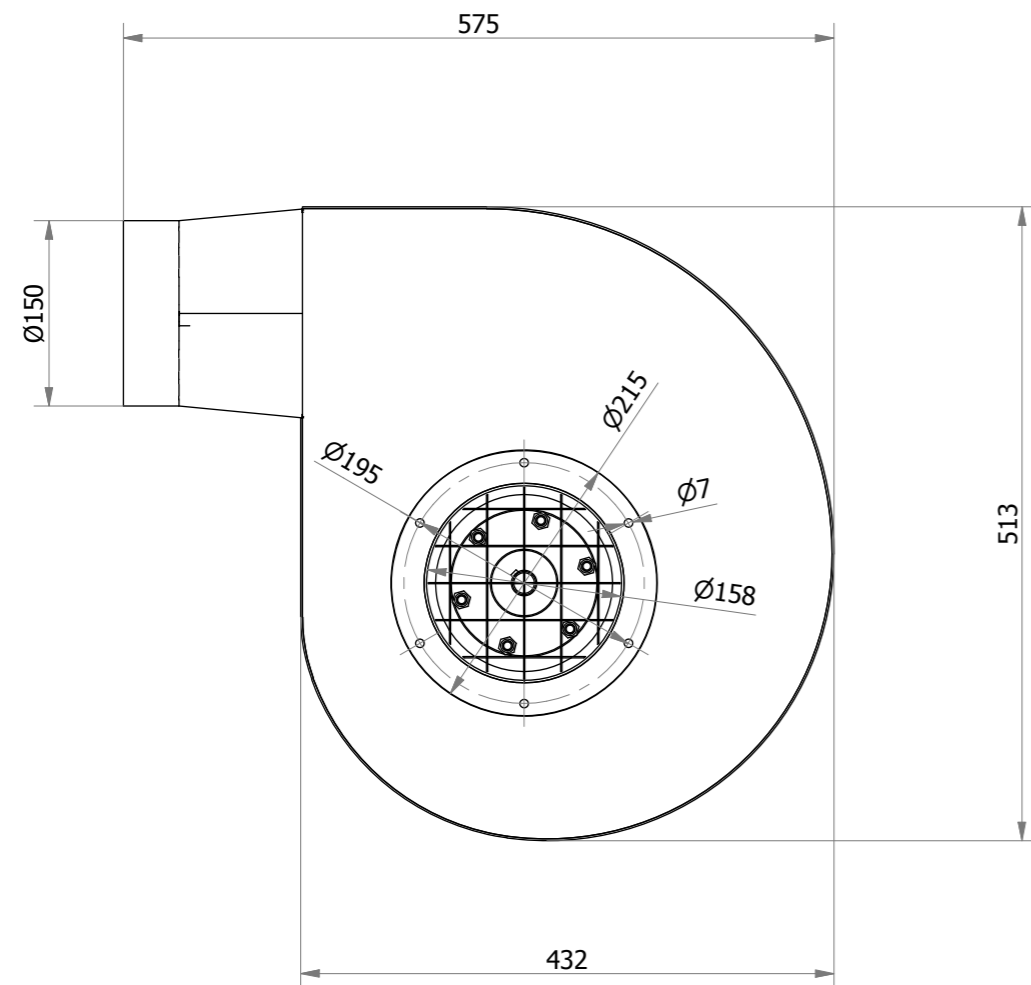

ZWR-03 with WS-160 wall mounting bracket

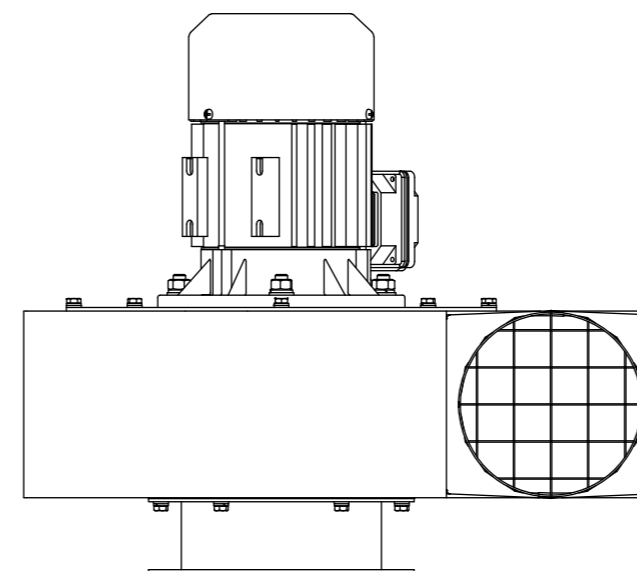
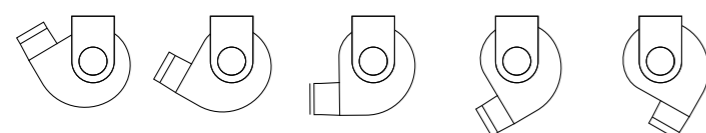

ZWR-03 with WSD-160 wall mounting bracket

