

OSKAR air products

www.oskarairproducts.com • info@oskarairproducts.com

Crawlair M - cartridge filter unit

303100017

- main filter cartridges 12 m²
- fan 1,1 kW, 50 Hz, 3-phase, 400 V

Mobile filter unit designed for continuous operation for most applications.

Standard construction:

- aluminum impeller 1,1 kW fan unit
- two stage filtration
- standard manual compressed air cartridge cleaning system
- standard dust drawer
- heavy duty welded and powder coated construction
- power cord holder
- 10 litre compressed air tank
- rubber mat

Parameters:

nominal airflow:	1000 m ³ /h
main filter surface:	12 m ²
weight:	110 kg
power supply:	3 x 400V / 50Hz
motor power:	1,1 kW
rated current:	2,7 A

Accessories and options:

- Oskar fume arm 1617P, reach 1,7 m, hood inlet 315 mm
- Oskar fume arm 1620P, reach 2 m, hood inlet 315 mm
- Oskar fume arm 1630P, reach 3 m, hood inlet 315 mm
- timer controlled compressed air cleaning system

Spare parts:

- polyester cartridge 6 m²
- metal mesh pre-filter
- swivel caster with brake 125
- fixed wheel 125

The method of packing and carton sizes:

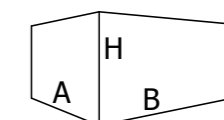

A = 610
B = 1200
H = 1050
waga = 110kg

All dimensions are given in **mm**.

Menegon Sp z o.o.
Mokry Dwór 6C, 80-021 Wiślnia, Polska
tel.: +48 58 3012838, fax +48 58 3059324
info@menegon.com.pl, www.menegon.com.pl

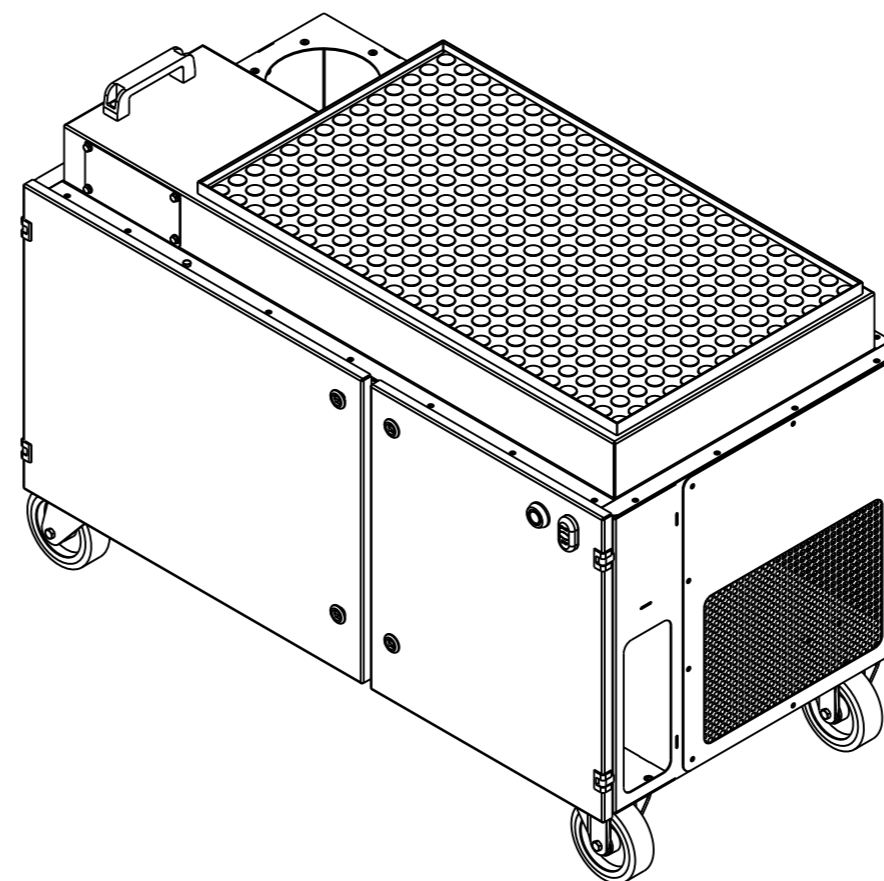
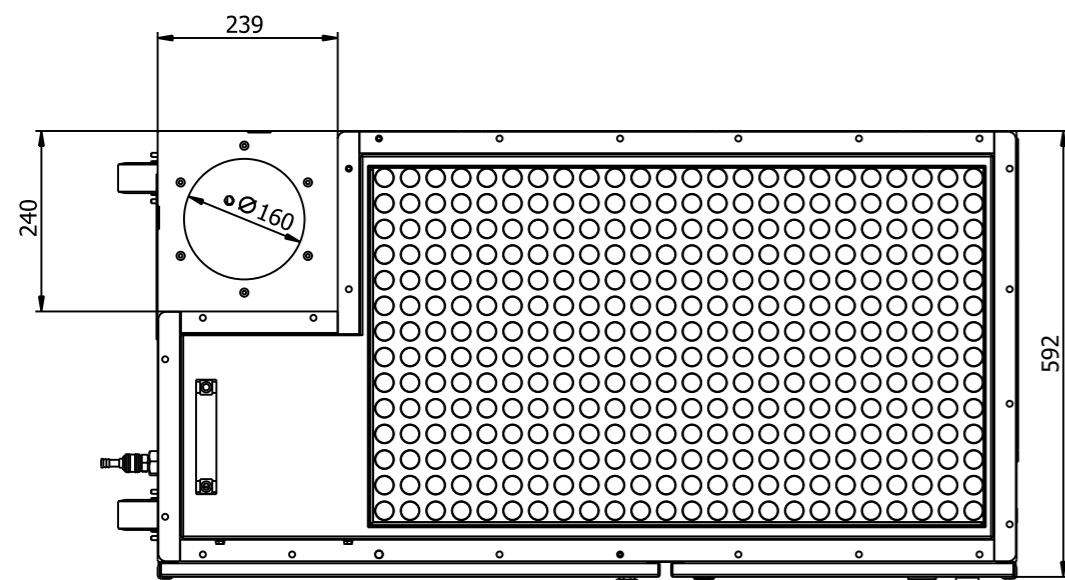
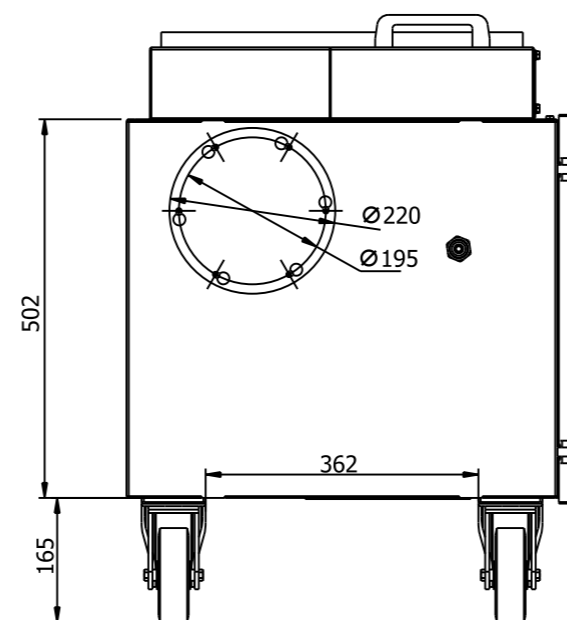
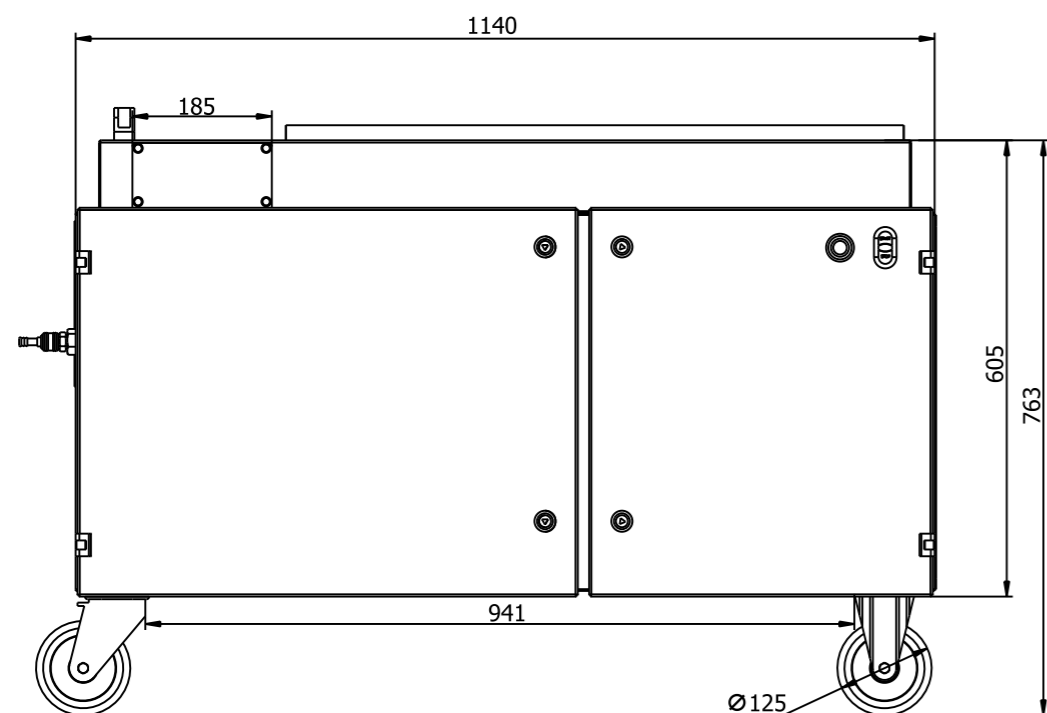

All rights reserved. This document including constructional and technical information as well as Oskar Air Products, Menegon and czystepowietrze.pl trademarks and brand names are law protected and are property of Menegon Sp. z o.o.